

# P10629 SEN-MW-PSC-BL-U-FM-DC0 | Dimming Ultrasonic Sensor

## Overview

- Ultrasonic sensor 40KHz ± 1kHz.
- 0-10V configurable output: set to 0%, 10%, 25% or 50% dimming
- Photocell for daylight sensing
- Time delay adjustable 1 min, 5 min, 20 min
- LED Motion indicator
- Active High/Low outputs for Relay drive
- Bluetooth add-on enables remote sensor programming with greater customization of dimming levels, and time delays.
- Test Mode

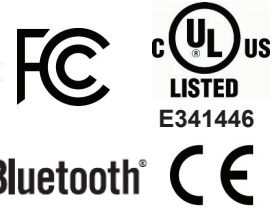

Suitable for indoor use

## Applications

The SEN-MW-PSC-BL-U-FM-DC0 is an ultrasonic sensor. It actively emits high frequency sound waves (40kHz) and uses the Doppler Effect to detect motion.

The SEN-MW-PSC-BL-U-FM-DC0 is a Class 2 Device designed to satisfy new CA Title 24 requirements for dimming of lighting fixtures. Using a 0-10V signal, the sensor is capable of

dimming lighting loads down to 0%\*, 10%, 25%, or 50%.

The sensor is suitable for a variety of indoor applications. It supports fixture and ceiling mounts from 8-12ft (2.4-3.7m) high. Both sensor and power pack are rated for use in temperatures ranging from -30° to 70°C and relative humidity from 90 to 95% at 30°C.

\*For dim to off, LED dimming driver capable of dimming to off is required.

## Sensor Operation

End users can manually program length of time delays, sensor range and dimming level using a series of dipswitches and trimpots.

**Dimming:** 0-10V dimmer connects to 0-10V control on the LED driver. When motion is detected the sensor will bring lighting up to 100% lumen output. When no motion is detected for the length of selected Time Delay, the sensor will send a signal to dim lighting to a specific level set by the end-user.

**Test Mode:** Test Mode sets the time delay to five seconds and runs for 5 minutes. LED flashed 2 times to indicate Test Mode started. After 5 minutes (or push the Test Mode button again), LED flashed 3 times, the sensor returns to the selected time delay. During test mode, full output when triggered, and dimming level reflects the dip switch setting.

**Relay Control:** Two additional High and Low motion outputs can be used to control relays or other control circuitry.

**Optional Bluetooth smart and Bluetooth mesh:** The Bluetooth Low Energy (BLE) enabled version pairs with an Android or iOS application to allow initial setup and subsequent sensor adjustments, beyond what the analog controls on the sensor can offer. The mobile application enables adjustment of sensor parameters such as time delay, dim level, sensitivity, daylight detection, and more. Additionally, features such as parameter profiles, manual dim control, and real-time feedback from the sensor can speed up

## Accessories

**Power Pack:** The SEN-MW-PSC-BL-U-FM-DC0 operates on 12 VDC input and requires a separate power pack. Alternatively, the sensor can also operate with a driver that has an auxiliary output (12V).

## How to Order

™

Model No.	Description	Input Voltage	Output
P10629 SEN-MW-PSC-BL-U-FM-DC0	Diming Ultrasonic Occupancy Sensor	12 VDC	0-10VDC Motion High Motion Low

Summary	
Sensor Type	Ultrasonic occupancy sensor
Input Voltage   Current Consumption	12 VDC   45mA sensor (70mA w/ BLE)
0-10V Output	100mA lowest dimming voltage 0.05V max.
High	Vin-2.5V 100mA source
Low	100mA sink current
Mounting Height	Fixture-Wall Mount or ceiling mount at 8-12ft (2.4-3.7m) high
[Low/Med/High] Max Range* (Wall Mounted)	13ft (4.0m) / 18ft (5.5m) / 35ft (10.7m)
Time Delay**	1min, 5min, 20min
Photocell Sensitivity **	N/A
Max Bluetooth Range***	49 ~ 65ft (15 ~ 20m)
Operating Temperature	-30° C to 70° C
Storage Temperature	-40° C to 80° C
Relative Humidity	90-95% non-condensing at 30° C
Color	White
Warranty	5 years

\*Results may vary based on mounting height, angle, floor material, and line of sight  
 \*\*Second time delay and Photocell can be activated through optional Bluetooth version only. \*\*Bluetooth versions enable adjustment of sensor parameters such as time delays, dim level, sensitivity, ON/OFF daylight detection, and more.  
 \*\*\*Bluetooth Range is highly dependent on the integration of fixtures, surrounding environment and conditions. It is recommended to conduct testing for range accuracy.

Physical Dimensions

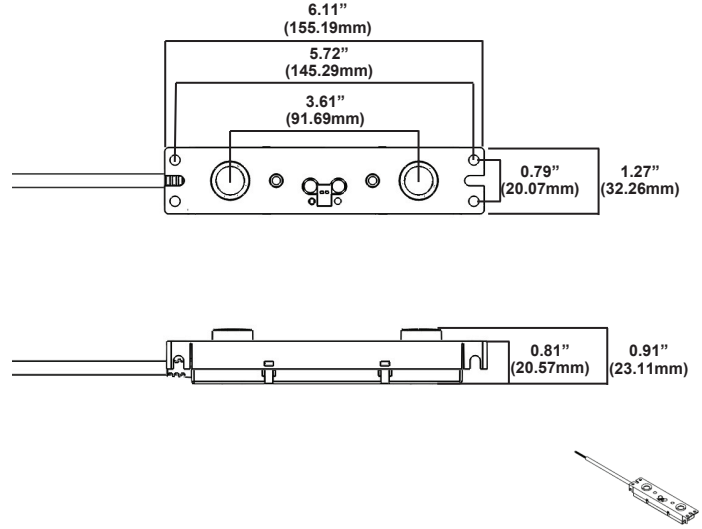

Drawings are Not to Scale

Wiring Diagram

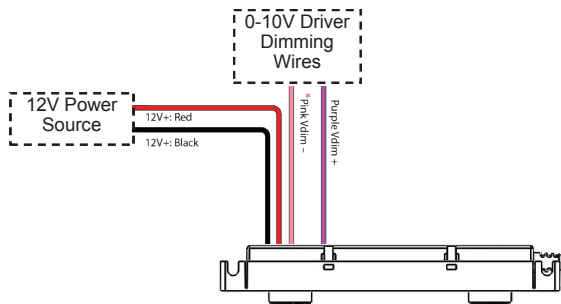

Detection Area for 7.9ft (2.4m) Ceiling Mounted

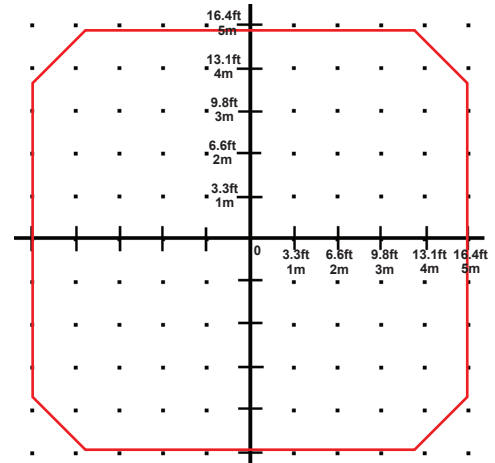

Settings Adjustment

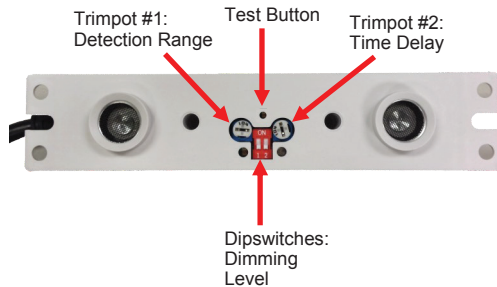

**Trimpot #1** on left adjusts motion detection range and sensitivity.  
**Trimpot #2** on right adjusts time delay. Turn clockwise to increase, turn counterclockwise to decrease.

**Test Button** sets the time delay to five seconds and runs for 5 minutes. LED flashed 2 times to indicate Test Mode started. After 5 minutes (or push the Test Mode button again), LED flashed 3 times, the sensor returns to the selected Trimpot time delay setting.



Dipswitch 1	Dipswitch 2	DIM Level
OFF	OFF	OFF
OFF	ON	10%
ON	OFF	25%
ON	ON	50%

Leads: Minimum 22AWG

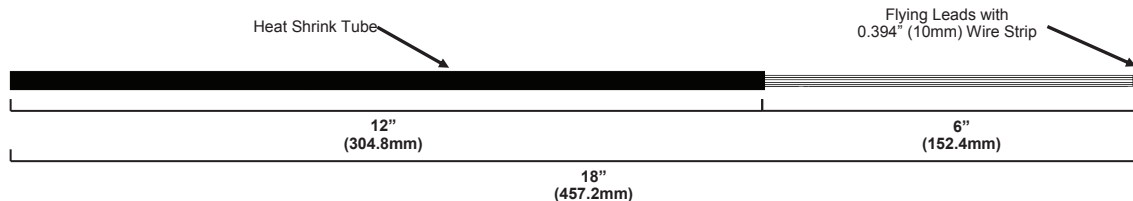

Tolerance ±1" (25.4mm)